



New Ways of Looking at Authority Data

III Encuentro Internacional de Catalogadores Tendencias Actuales en la Organización de la Información

**Biblioteca Nacional de la República Argentina
Buenos Aires, November 2007**

**Glenn Patton
Chair, IFLA FRANAR Working Group**



Convergence in 1998

- FRBR – “the need to extend the model ... to cover authority data”
- IFLA Working Group on Minimal Level Authority Records and ISADN
- International Conference on National Bibliographic Services



FRANAR Working Group

Functional
Requirements
And
Numbering of
Authority Records



Working Group Members

- Françoise Bourdon
- Christina Hengel-Dittrich
- Olga Lavrenova
- Andrew MacEwan
- Eeva Murtomaa
- Glenn Patton
- Henry Snyder
- Barbara Tillett
- Hartmut Walravens
- Mirna Willer
- Tom Delsey
- Marie-France Plassard



Terms of Reference

1. To define functional requirements of authority records
2. To study the feasibility of an International Standard Authority Data Number
3. To serve as the official IFLA liaison to and work with other interested groups concerning authority files



The Goal of the Model

- To provide an understanding of how authority data functions currently
- To clarify the underlying concepts to provide a basis for refining and improving on current practice in the future



Functions of the Authority File

- 1) Document decisions
- 2) Serve as reference tool
- 3) Control forms of access points
- 4) Support access to bibliographic file
- 5) Link bibliographic and authority files

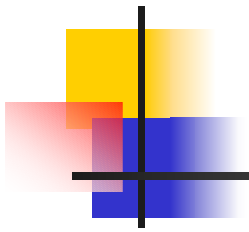



Users

- Authority data creators and reference librarians

- Library patrons



Users

- Authority record creators and reference librarians
- Library patrons

User Tasks

- Find
- Identify
- Contextualize
- Justify

**Bibliographic
Entities**

known by

**Names and/or
Identifiers**

basis for

**Controlled Access
Points**

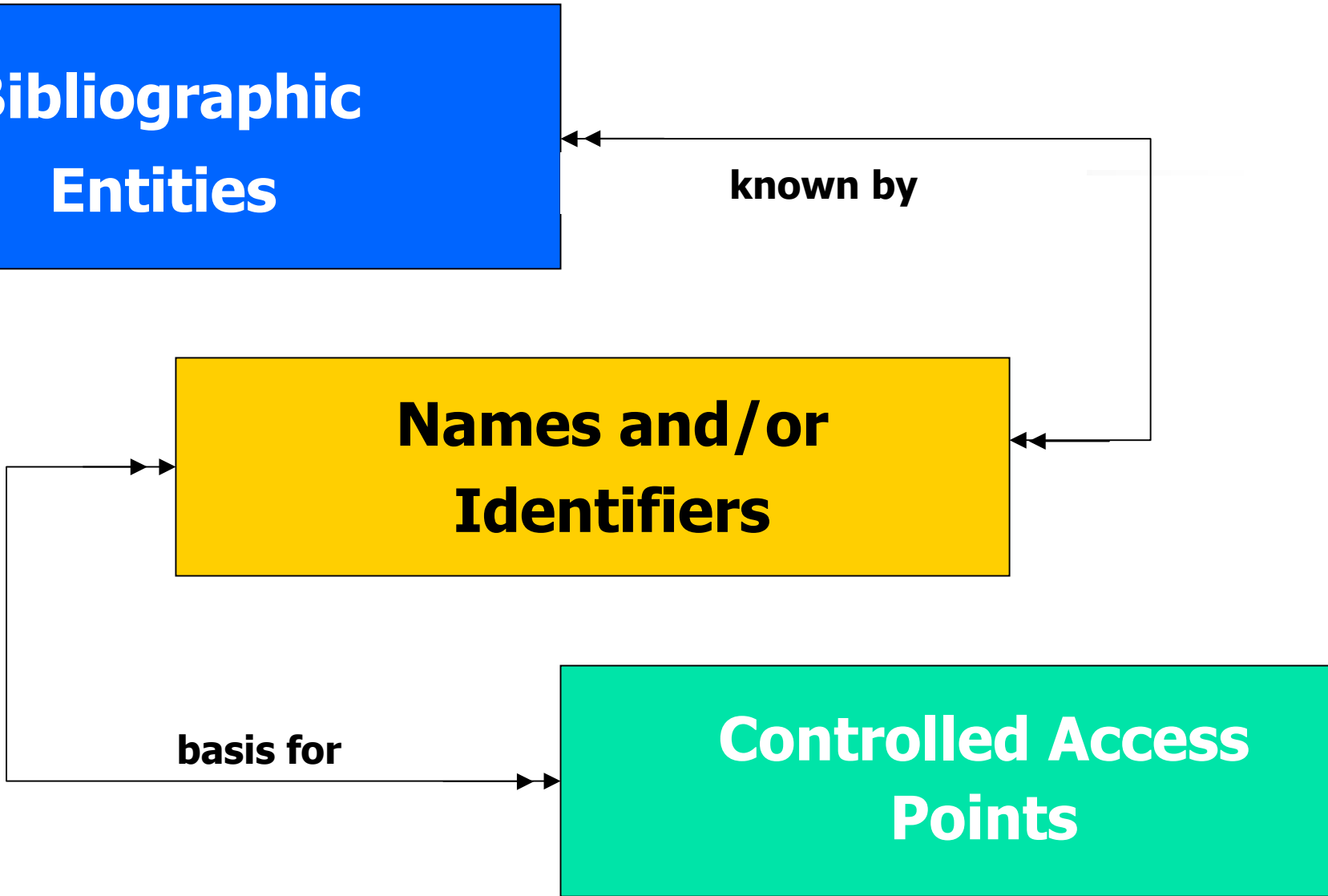

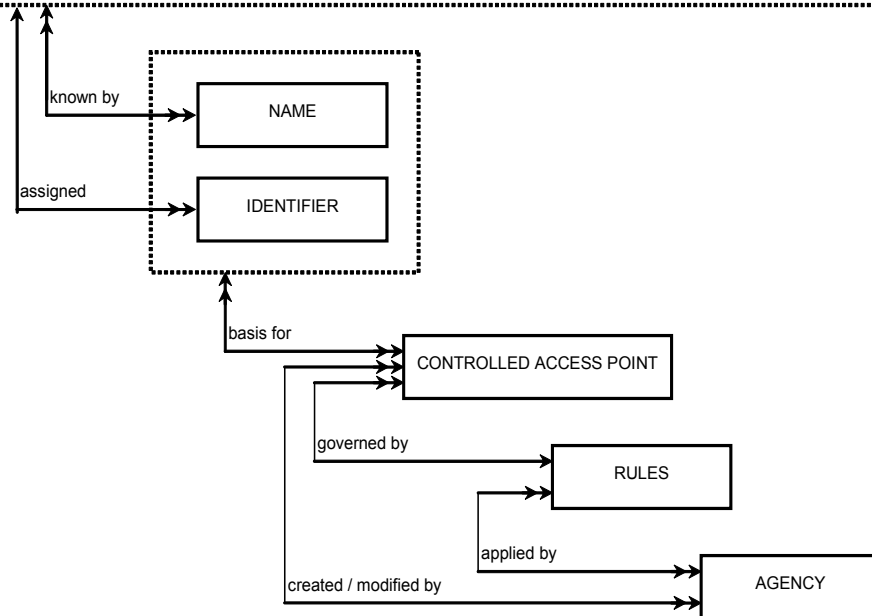
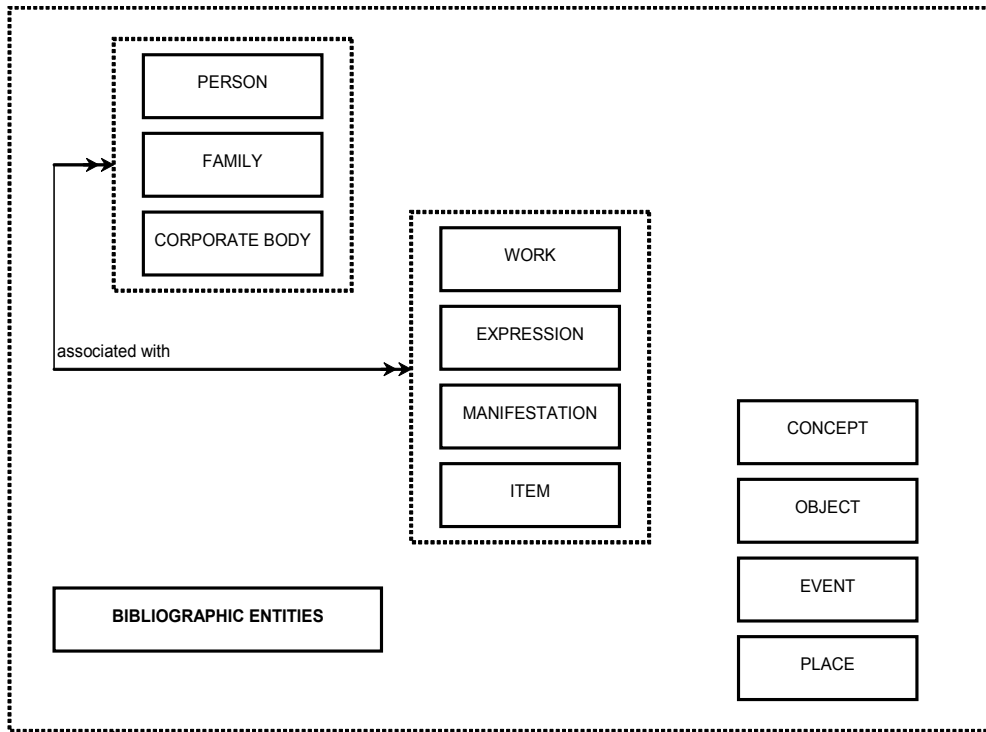

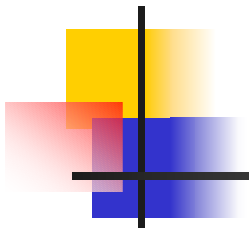

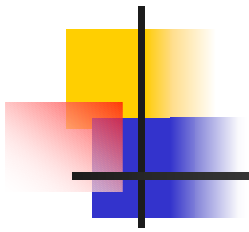

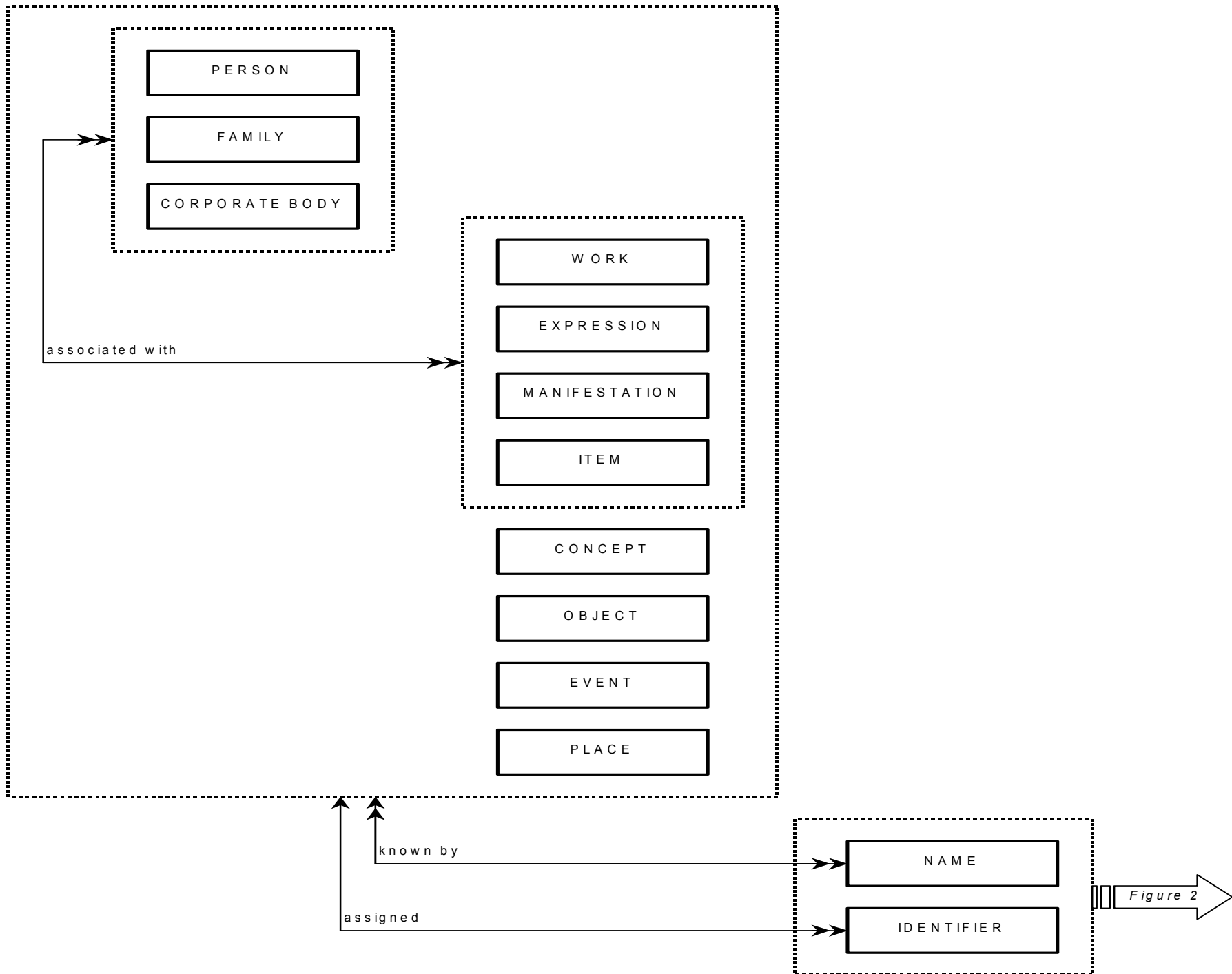
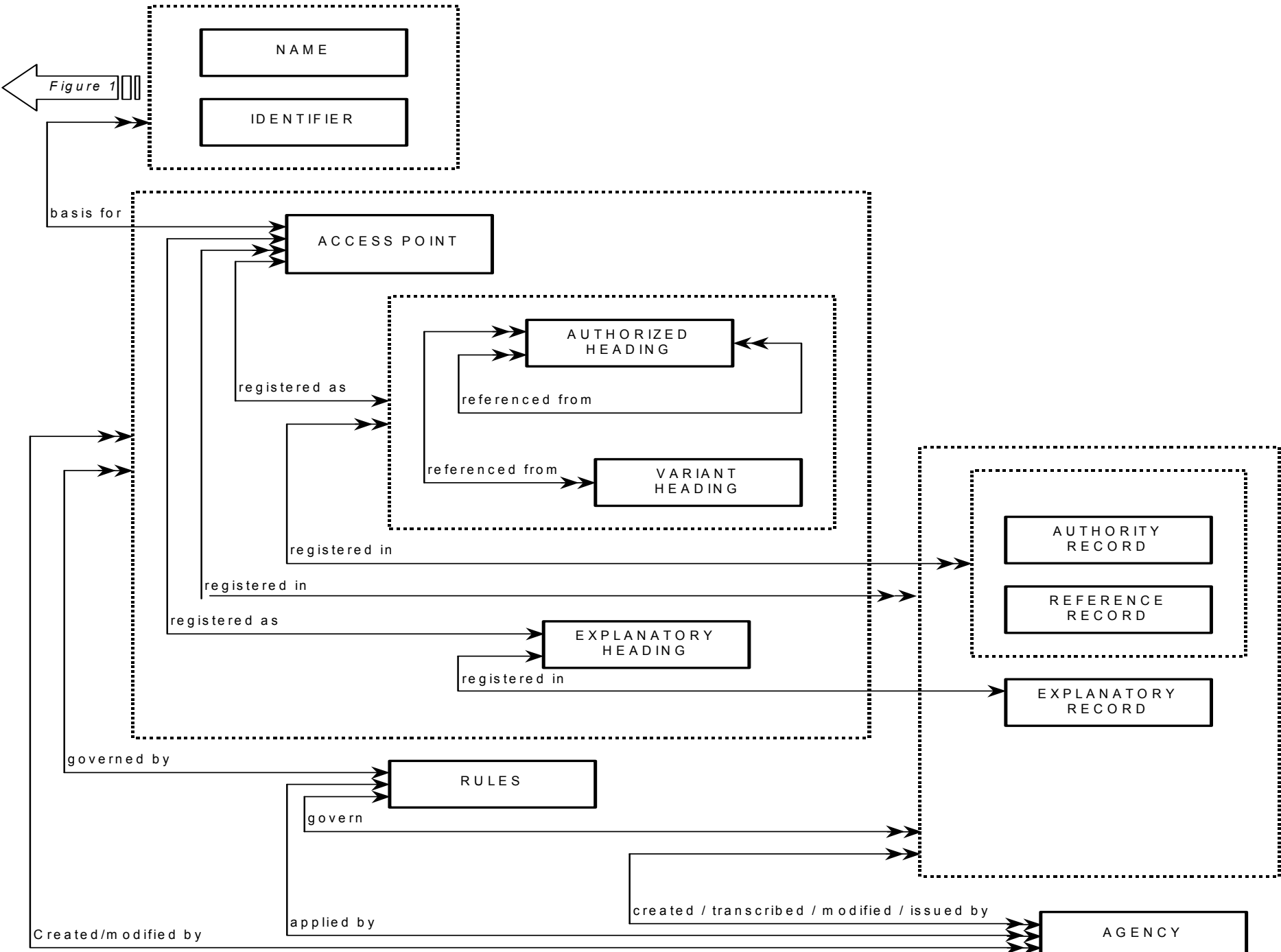

Figure 2





Entities & attributes (1)

- Person

- An individual or a persona established or adopted by an individual or group

- [FRBR, modified]

- *Dates of a person*
- *Title of person*
- *Place of birth*
- *Language of person*
- *Field of activity*
- [etc.]*



Entities & attributes (2)

- Name

- A character or group of words and/or characters by which an entity is known
[FRBR, modified]

- *Type of name*
- *Scope of usage*
- *Dates of usage*
- *Language of name*
- *Script of name*
- *Transliteration scheme of name*
[etc.]



Entities & attributes (3)

- Controlled access point

- A name, term, code, etc. under which bibliographic or authority record or reference will be found.

- [GARR, modified]

- *Type of access point*
- *Language of cataloguing*
- *Script of cataloguing*
- *Source of access point*
- [etc.]*



Relationships (1)

Work \Leftrightarrow Work

- Successor relationship
- Adaptation relationship
- Transformation relationship
- Whole/part relationship
[etc.]



Relationships (1)

Work \Leftrightarrow Work

- Transformation relationship

Example:

The relationship between the musical work, *La chute de la maison Usher* by Claude Debussy, and the literary work on which it is based, *The fall of the house of Usher* by Edgar Allen Poe.



Relationships (2)

Person \Leftrightarrow Name

- Real name relationship
- Pseudonym relationship
- Married name relationship
- Secular name relationship
[etc.]



Relationships (2)

Person \Rightarrow Name

- Pseudonym relationship

Example:

The relationship between the person whose real name is Eric Arthur Blair and the name he used for his literary works, George Orwell.



Relationships (3)

Controlled access point \Leftrightarrow Controlled access point

- Parallel language relationship
- Alternate script relationship
- Different rules relationship



Relationships (3)

Controlled Access point \Leftrightarrow Controlled Access point

- Alternate script relationship

Example:

The relationship between the controlled access point for “Gogol, Nikolai Vasilievitch” written in Latin alphabet and the controlled access point for “Гоголь, Николай Васильевич” written in the Cyrillic alphabet



What's Next?

- Resolution of comments from the worldwide review
- Publication of the FRAR model
- Completion of recommendations on numbering
- Recommendations for changes to existing IFLA publications

